



DIVERSI-TECH inc.

Fred

OWNER'S MANUAL

MODELS - FRED 02



IMPORTANT

This manual contains specific cautionary statements relative to worker safety. Read this manual thoroughly and follow as directed. Hazards of dust control equipment are not all listed in this manual. It is important that use of the equipment be discussed with a Diversi-tech Representative. Persons involved with the equipment or systems should be instructed to operate in a safe manner.

Table of Contents

Upon Arrival.....	3
Installation	3
Filter Maintenance	3-4
Exploded View	5
Options & Replacement Parts	5
Wiring Diagram	6
Warranty.....	7



Caution

Avoid mixing combustible materials, such as buffing lint, paper, wood, aluminum, and magnesium dust, and with dust generate from grinding ferrous metals due to the potential fire hazard caused by sparks in the dust collector.

All users of Diversi-tech Equipment should comply with all National and Local Fire Codes and / or other appropriate codes when determining the location and operation of dust control equipment.

Upon Arrival

The Fred O2 portable is shipped on a crated skid and comes with 2 capture arms (6" x 10'long). The skid should be inspected for any visible damage that may have occurred during shipment. If the Fred O2 appears to have been damaged during shipping, please advise transport company as soon as possible.

Start Up

- 1) The unit is equipped with a rotary motor starter, located on top of the unit.
- 2) Correctly size electrical supply cable according to motor horsepower and voltage.
- 3) Supply voltage must be connected to the line side of the contactor (L1, L2, L3). The ground wire must also be grounded to the cabinet.
- 4) The supply cable must be pulled through an air tight connector and tightly secured.
- 5) Check amperage. Amperage should never exceed the rated motor amperage for more than a few moments.
- 6) Make sure that the filter cartridge is in the unit. Any other optional filters should be verified as well. If a minihelic gauge was ordered, make sure that the dial reads between 0" and 0.5" w.c (with clean filter cartridge)
- 7) Both Capture arm are to be mounted and well secured to the top of the unit.
- 8) Note: This is a 3-phase motor starter. To ensure you have proper motor rotation, refer to the directional arrow on th motor plate (which should indicate clockwise)

Warning: Always disconnect power supply before servicing the blower wheel & motor or working with the unit for any reason.

If all above is in order, Your Fred O2 is ready to be put to use.

Maintenance

Filter Cartridges

The filter cartridge should be cleaned as required. This cleaning should take place when suction is insufficient.

In order to clean the cartridge, it must be removed. To do so, remove the door panel furthest from the inlet and release the latch on the cartridge locking mechanism located under the filter cartridge. The cartridge should then be turned horizontally and tapped lightly on a solid surface. (This can be done directly into a plastic garbage bag)

As second step the cartridge should be cleaned with compressed air. The air should travel radially inward (from the outside of the cartridge to the interior). It is recommended that this procedure be done outside or in a well ventilated area.

Warning

Cleaning should be carried out on water-soluble materials only. Hydrocarbons may not be removable. The use of solvents may attack certain components of the filter, thus consultation of the manufacturer is required. Do not attempt to clean filters containing hazardous materials, be aware that all sewage and waste ordinances have been followed. The filter is of paper-pleat material, do not attempt to wash the filters. Do not wet or clean the cartridge with any liquid, as it may cause the forming of unwanted blockage on the filter media. The cartridge may be weakened causing perforations to the media and ultimately damage of the blower. If after cleaning the filter cartridge the system rapidly loses performance again it might be a sign that the filter cartridge needs to be replaced. The cartridge life is estimated to be 6 to 12 months depending on the application and frequency of usage.

Carbon Filter

The carbon filter is located in the rear mesh door panel. This panel aids in absorbing most gases and odors out of the air stream. This panel needs to be replaced every 12-18 months or when the odors become apparent. As a good practice, this filter should be replaced every time the filter cartridge is replaced. To replace, remove mesh door from unit, tear out old carbon panel, and install new panel by applying a couple of dabs of contact cement or other glue on the outside edge of the panel facing the door. The glue is only necessary to hold up the panel when re-installing the mesh door.

Capture Arms

Adjustment to arm friction joints can be made by tightening or loosening the bolts that fasten the pads to the aluminum frame. This will permit the arm to maintain its position.

HEPA Filter

For units equipped with a HEPA filter, it is necessary to pay attention to change in emissions to determine filter efficiency. The filter will need to be changed when its loading capacity will have been reached. This will be apparent when having poor suction at the capture arm even after going through a complete main cartridge cleaning cycle. To make a definite determination of the filter loading, remove the HEPA filter from the unit. If the performance improves, the HEPA filter is at fault. If not, the main cartridge is to be properly cleaned or replaced. **DO NOT CLEAN THE HEPA FILTER.** When completely loaded, this filter must be disposed of carefully. The particulate matter it contains should not be allowed to return back into the atmosphere.

Exploded view diagram

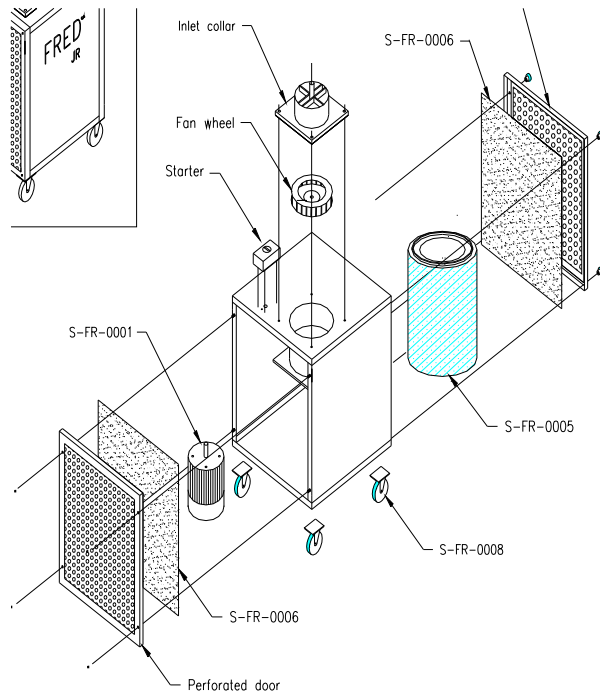

Options

Part

Description

O-IA-LK	Upgrade: Halogen Light Kit in 2 suction hoods
O-IA-PC	Pneumatic Castors 6" (with set of 4 spider legs)
O-IA-CMP	Carbon Module: Impregnated Panel Type (4 panels)
O-IA-HFM	H.E.P.A. Filter (99.97%@0.3micron) & frame
O-IA-ARM13-2	Upgrade both capture arms to 13' long
O-IA-RP	Replace ICS Cleaning System with Reverse Pulse Self Cleaning
O-IA-POLY	Upgrade to Polyester Spun Bond filter cartridge

Replacement Parts

Part

Description

S-IA-0002	7.5HP Motor (3 phase - specify voltage)
S-IA-0003	Standard 21" Filter Cartridge 280 ft ² (open both ends)
S-IA-0003-P	21" Polyester Filter Cartridge 280 ft ² (open both ends)
S-IA-0004	7.5HP Starter w/Auxiliary Contact (specify voltage)
S-IA-0005	Cleaning System Controller Board - Model IC-3
S-IA-0007	7.5HP B.I. Blower Wheel
S-IA-0009	Activated Carbon Panel
S-IA-0011	H.E.P.A. Filter 99.97%@0.3micron
S-IA-0012	Step down Transformer (specify voltage)
S-IA-0013	Castors (set of 4)
S-IA-0016	1/4" Pneumatic Filter
S-IA-0018	Self-Cleaning System (Proximity Sensor Model)
S-IA-0027	Solenoid Valve (12 VAC)
S-IA-0028	Suction hood 6"

Wiring Diagram for 7.5HP 230/460/575/3/60

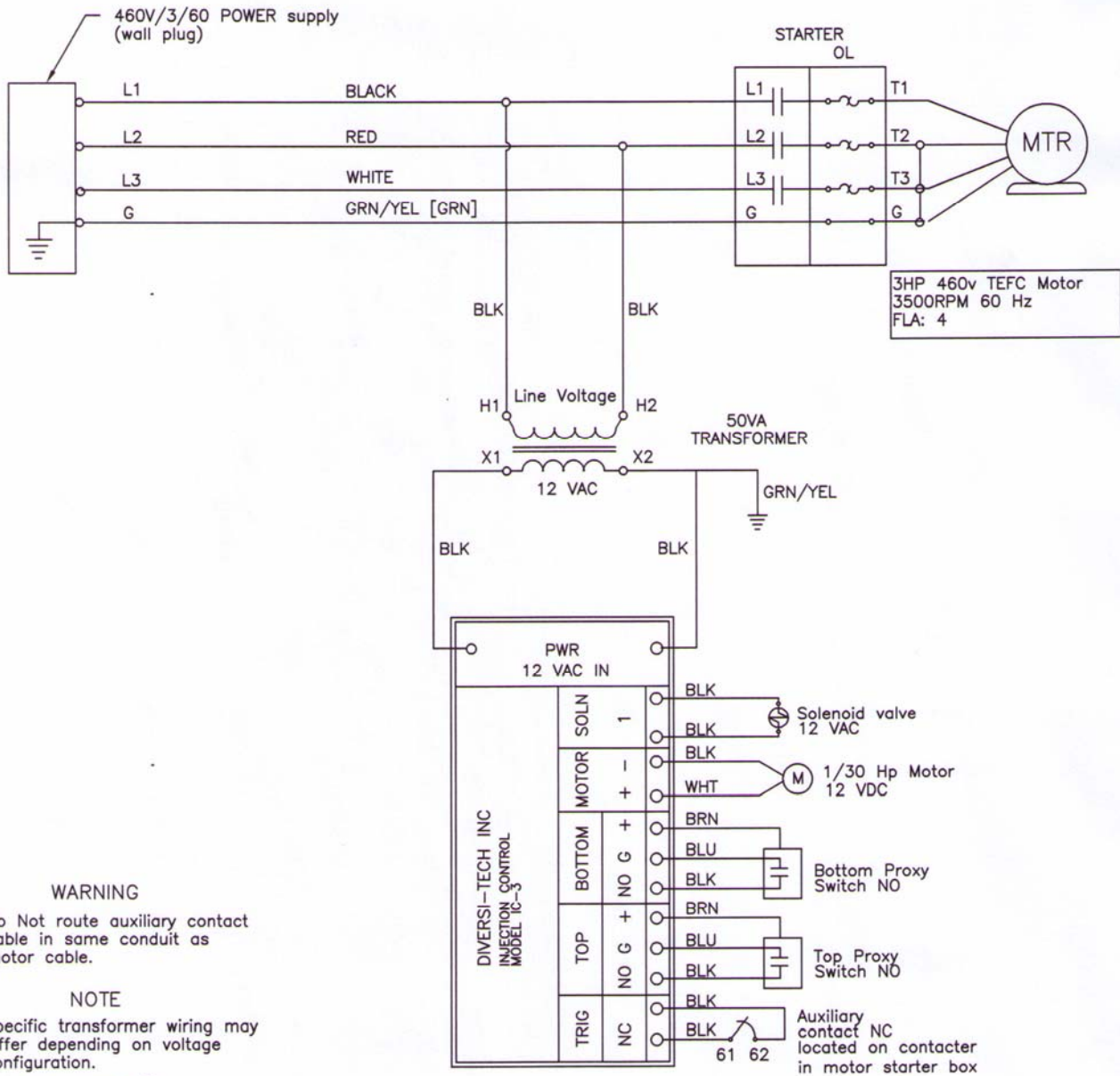

WARNING

Do Not route auxiliary contact cable in same conduit as motor cable.

NOTE

Specific transformer wiring may differ depending on voltage configuration.

Units in brackets [] refer to imperial system values

WARRANTY

Effective immediately, the following policy will apply to all equipment.

LIMITED EQUIPMENT WARRANTY

All Diversi-Tech units are warranted to be free from defects in material for a period of two years from the date of purchase. Diversi-Tech Inc. will repair, at our option, any defective parts returned to the manufacturer's plant in Montreal - Quebec freight prepaid- which fail during the warranty period. This warranty is limited to replacement parts ONLY, subject to on site or in house evaluation of defective materials and does not apply to any personal liability or property loss that occurs due to the use or installation of this equipment.

FREIGHT CLAIMS

All Diversi-Tech units are sold ex-plant, Montreal, Qc., Canada. Therefore, it is the user's responsibility to file any freight claims for obvious or concealed damages which developed in transit from Montreal to your location or when drop shipped.

RETURN MATERIAL POLICY

1. Prior to the return of material, for whatever reason, a return manufacturing authorization number (RMA#) is required from the Diversi-Tech production control department.

This procedure is necessary for proper control and handling of returned materials. Fax us or call to obtain the RMA.

2. All material must be returned prepaid. Credit will be given for returns for warranty replacement. Freight collect shipments will not be accepted.

It is the shipper's responsibility to insure that material being returned to Diversi-Tech is adequately packaged for shipment to preclude damages.

DIVERSI-TECH
2025 52ND AVENUE – LACHINE, QC. H8T 3C3
1-800-361-3733 – FAX: (514) 631-9480

www.diversitech.ca – info@diversitech.ca